

140x140x25mm

■ Model E

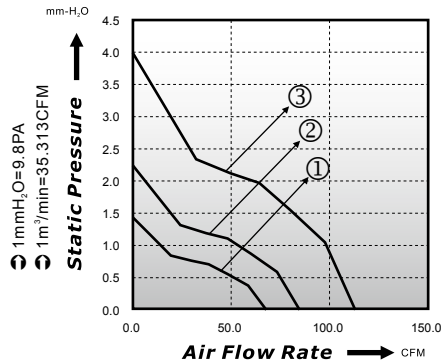

■ P-Q Curve (At Rated Voltage)



■ Dimensions Drawing

Unit: (mm)

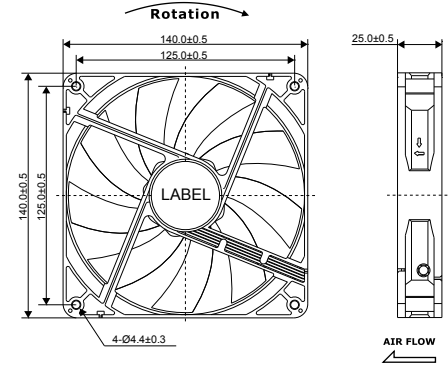

Model No	Bearing (*)	Rated Voltage (VDC)	Rated Current (A)	Power Consumption (Watts)	Speed (rpm)	Air Flow (CFM)	Static Pressure (mmH ₂ O)	Noise (dBA)	Curve
ED14025-12L*	○ ● ⊖	12	0.30	3.6	1200	67.9	1.44	27.7	1
ED14025-12M*	○ ● ⊖	12	0.40	4.8	1500	84.8	2.24	32.5	2
ED14025-12H*	○ ● ⊖	12	0.50	6.0	2000	113.1	3.99	42.3	3
ED14025-24L*	○ ● ⊖	24	0.20	4.8	1200	67.9	1.44	27.7	1
ED14025-24M*	○ ● ⊖	24	0.30	7.2	1500	84.8	2.24	32.5	2
ED14025-24H*	○ ● ⊖	24	0.40	9.6	2000	113.1	3.99	42.3	3

* Bearing Type: ○ Sleeve ● Two Ball ⊖ Hydro-Dynamic